

# A600

All you need for perfect coffee



MAKE IT  
*Wonderful!*

**FRANKE**

# TRUE PASSION LEADS TO INNOVATION

Every Franke coffee machine is packed with true passion and 100 percent Swissness. During product development, we learn from the experiences of restaurant operators, study the needs of coffee roasters and coffee lovers, and work tirelessly to further improve our products. The latest product resulting from this constant drive for innovation is the new A600.

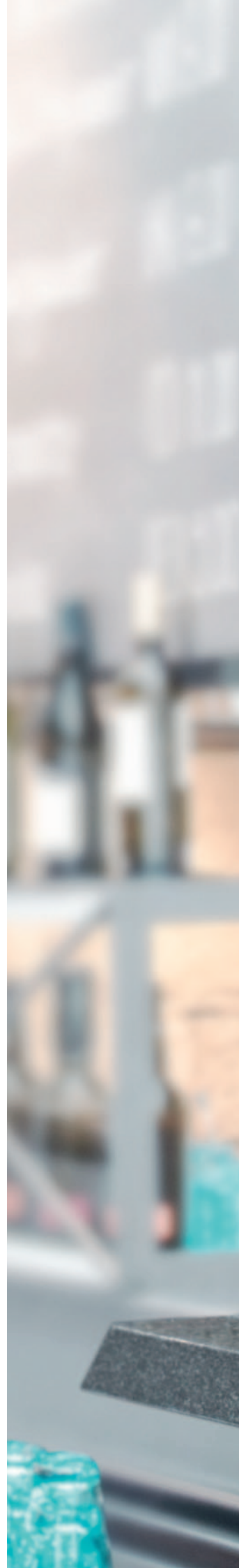







FRANKE

Mon 12:11  
Nov 14th

 <i>Espresso</i>	 <i>Ristretto</i>	 <i>Espresso Macchiato</i>	 <i>Brewed Coffee</i>
 <i>Cappuccino</i>	 <i>Cinnamon Cappuccino</i>	 <i>Vanilla Cappuccino</i>	 <i>Latte Macchiato</i>
 <i>Vanilla Latte Macchiato</i>	 <i>Milky Coffee</i>	 <i>Chocolate</i>	 <i>Tea</i>

Inspire me



Quick Select

FRANKE

# INTELLIGENT AND USER FRIENDLY

As a truly intelligent coffee machine, the A600 redefines how you interact with it. Enormously flexible, this perfect interaction dramatically improves efficiency in professional use.

The eight-inch color touchscreen with crystal clear resolution is the perfect interface for you and your guests. Intuitive menu prompts result in straightforward, efficient operation. The selection of beverages can be set individually and adapted to your exact requirements. Achieve additional sales through the exceptionally easy placement of advertising messages and evocative images on the display. The ideal user interface is at your disposal to address every possible application and use.

## **Intuitive overview for self-service operation**

Using a clearly understandable grid, guests place their order from an attractive menu of beverages. This can be customized easily with your own images. The desired beverage can be selected in the blink of an eye with a simple touch or swipe of a finger, and it's just as easy to set the cup size and the desired flavor.

## **Inspiring impressions of enjoyment**

The large-format category overview tempts the user into selecting their own beverage creation. Inspiring images awake curiosity and invite them to explore an almost limitless range of beverages.

## **Efficient support in service**

Large orders can be entered simply in a single step and then prepared one after the other at the touch of a button. This method supports service personnel and reduces their workload, reduces mistakes and makes it possible to exploit the full capacity of your machine.

## **Functional lighting concept for total control**

The newly developed LED lighting concept not only gives the central display a stylish appearance, it also issues warning messages (such as "Caution: hot drink being prepared") and operator messages (such as "Add coffee beans or milk" or "Empty the coffee grounds container"). This gives you total control at all times and at any distance.





# THE DETAILS MAKE THE DIFFERENCE

SELECTION FROM THREE DIFFERENT BREWING UNITS - OPTIMALLY ADJUSTED TO YOUR WAY OF MAKING COFFEE

THE INTUITIVE TOUCHSCREEN MAKES OPERATION SIMPLE AND EFFICIENT, AND CAN BE CONFIGURED TO YOUR INDIVIDUAL REQUIREMENTS

FUNCTIONAL LIGHTING CONCEPT

PERMANENT WATER SUPPLY CONNECTION OR TANK (4 LITER) AVAILABLE

AUTOMATICALLY ADJUSTABLE BEVERAGE SPOUT

REMOVABLE DRIP TRAY (3 LITER) WITH LEVEL MONITOR

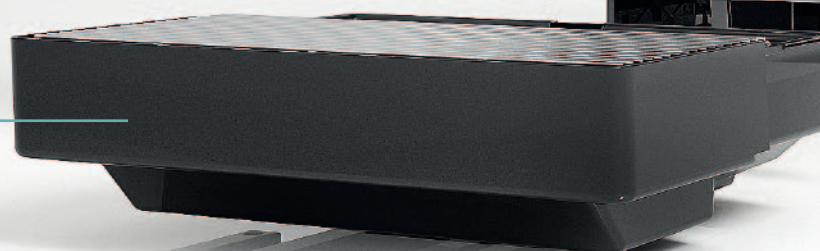
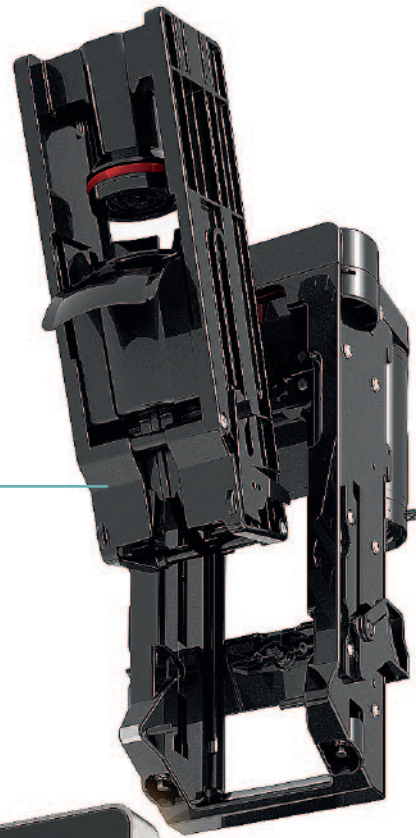

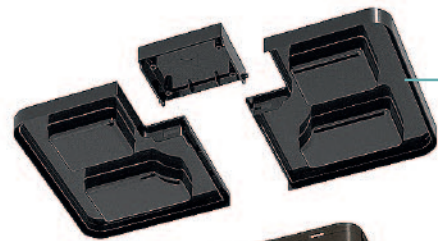

**LOCKABLE COVER (OPTIONAL)**

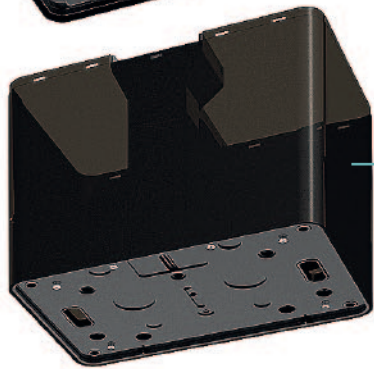

**GENEROUSLY SIZED BEAN  
HOPPER FOR SIMPLE REFILLING  
(2 × 1.2 OR 1 × 2 KG)**

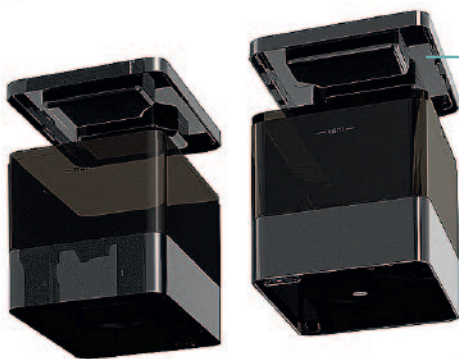

**TWO SEPARATE POWDER  
CONTAINERS (2 × 2.2 LITER)**

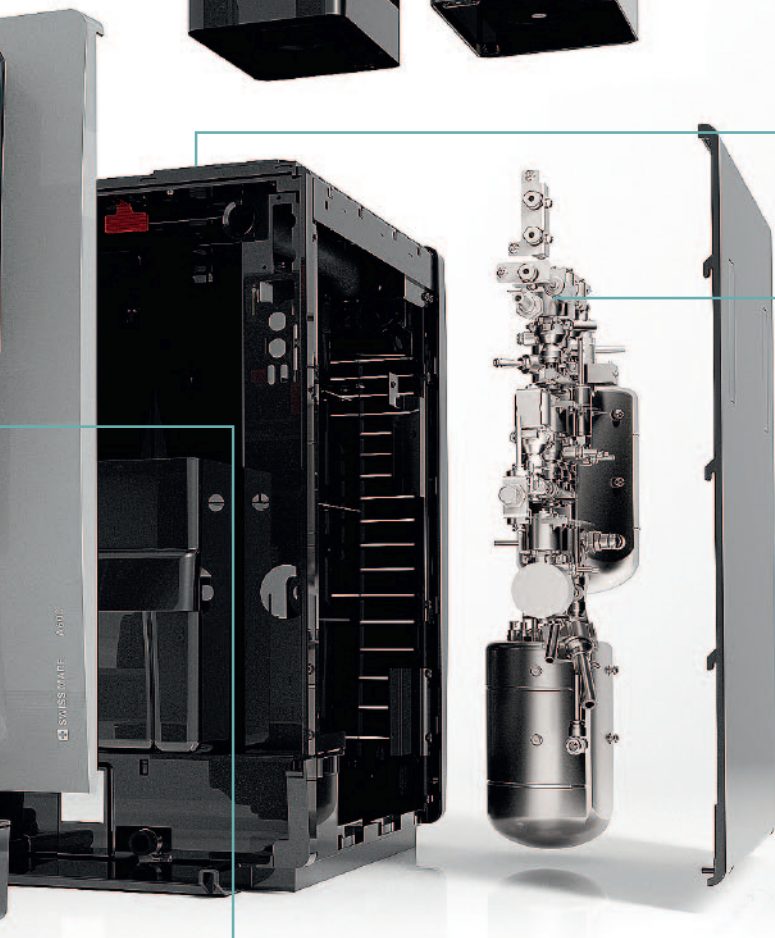

**SIMPLE SETTING OF  
GRINDING COARSENESS**

**MAXIMUM ENERGY  
EFFICIENCY THANKS TO  
A TIMER FUNCTION  
AND MINIMAL POWER  
CONSUMPTION IN STANDBY  
MODE**

**AUTOSTEAM /  
AUTOSTEAM PRO  
STEAM SPOUT**

# INNOVATIVE SWISS TECHNOLOGY FOR PERFECT COFFEE ENJOYMENT

When it comes to making coffee, the core process is and always will be extraction. Our researchers are always looking for increasingly sophisticated methods. This is exactly the reason why our coffee machines set such a high standard for others to meet. Our machines are a testament to true Swiss quality in every regard.

It is the essence that distinguishes a good cup of coffee from a superb one. Extraction is the deciding factor when brewing coffee, with the goal of getting the absolute best from the beans. The new A600 optimizes this process and ensures perfect results in every cup.

Franke has selected only the best components for the A600 and combined them to create a perfectly matched system. This consistency can be seen as soon as you open the practical, easily accessible bean hopper. Its shape ensures that the machine is extremely easy to fill, as well as making sure the beans continue to move optimally through the feeder.

The bean hopper can be removed easily using the central unlocking mechanism on the front of the machine. This then gives you direct access to the coarseness settings in the ceramic grinder – and all without the use of any tools. The precision grinding discs are extremely robust and have a long service life, which results in consistently uniform grinding results. A further innovation in the A600 is the brewing unit, which can also be replaced easily without any tools. The heart of this fully automatic machine can be removed with just a few clicks. You can select from three different brewing units according to your own specific needs:

- For predominately single cups of specialty coffees and for a perfect espresso: 43 mm brewing unit
- For predominately two cups at once and for large cups: 50 mm brewing unit
- For predominately brewed coffee and single cups of classic coffee: patented needle filter



Patented, easy-to-replace brewing unit





**BEAN HOPPER**

**PATENTED BREWING UNIT,  
REMOVABLE FROM THE FRONT**

**PRECISION BEAN GRINDER  
WITH LONG-LIFE CERAMIC BURRS**

# SIMPLE HANDLING FOR MAXIMUM HYGIENE

The A600 has a seamless connection to yet another Franke innovation – the FoamMaster™. With this advanced milk system, you can set the foam consistency for specific beverages. Thanks to the high-precision measuring and control of the milk temperature – using a temperature sensor located directly in the milk container – an unmatched consistent quality of the milk foam is guaranteed.

## **A new standard of convenience**

The FoamMaster™ also stands out from the crowd with its advanced integrated cleaning concept. It reduces effort to a minimum and guarantees clean, safe handling. Spilled milk or cleaning agent is now a thing of the past. The cleaning container is installed in place of the milk container. The cleaning process runs fully independently and the machine returns automatically to Standby mode when finished. You can now take a break without any worries!

## **Hygienic, practical milk container system**

- Hose-free docking system for the milk container
- Integrated sensor for efficiently measuring the milk temperature
- Integrated cleaning cartridge

## **Efficient cleaning process**

- Automated process with integrated cleaning cartridge
- Safe and practical thanks to a separate cleaning container
- Highest level of cleanliness thanks to specially developed milk and coffee cleaning agents
- Maximum convenience: the cleaning process is ended automatically by the machine
- Conforms to HACCP



**FOAMMASTER™  
ON/OFF SWITCH**

**MILK CONTAINER (5 LITER) WITH INTEGRATED  
TEMPERATURE SENSOR AND DOCKING SYSTEM**

**MILK TEMPERATURE  
DISPLAY**

**LOCKABLE**



**CLEANING CONTAINER WITH  
INTEGRATED DOCKING SYSTEM**



**THE CLEANING AGENT CARTRIDGE**

# ONLY PERFECTION IS GOOD ENOUGH

Our highest priority is the perfect beverage and thus satisfied customers. The A600 meets this high standard in every regard. You will be thrilled with the consummate taste experience.

## **Endless possibilities with hot and cold milk, hot and cold milk foam and flavors**

The FoamMaster™ is your key to virtually infinite beverage options, including flavored milk and coffee specialties – from a perfect latte macchiato through to a classic espresso or a refreshing strawberry milk – and much, much more. Thanks to the milk processing system, chocolate dosing system and Flavor-Station which holds up to three different syrups, it masters every possible drink option. Make your selection and indulge yourself!

## **Coffee**

From dark classics to milky beverages and flavored coffees, the A600 excels in creating all products from the world of coffee, and all with a quality, authenticity and precision that will excite any coffee lover.

## **Chocolate**

The double powder dosing system allows the use of two different chocolates and enables the preparation of all types of chocolate specialties. The FoamMaster™ creates the perfect mix of milk, creamy smooth foam and chocolate at the touch of a button.

## **Milk**

Enjoy hot and cold milk foam as if it has been prepared by hand in the consistency you prefer. The short foaming time is particularly gentle, and only uses the amount needed. This efficient milk foaming system reduces milk waste and can cut calorie content.

## **Flavor**

Thanks to the optional Flavor-Station, you can enhance your beverages with up to three different flavored syrups. Combine your coffee beverage or milk with your favorite flavor – the FoamMaster™ makes your drink come to life at the touch of a button, from a fruity milk drink to a warming caramel latte macchiato.





# AS INDIVIDUAL AS YOU



## MILK SYSTEMS

- FoamMaster™ (FM)\*: hot and cold milk & milk foam, individually adjustable consistency, integrated cleaning system
- Milk system (MS): hot and cold milk & warm milk foam, exact dosing via milk pump

## A600 OPTIONS

- Second bean grinder
- 2 × 1.2 kg bean hopper, lockable
- One or two separate powder dosing systems (for chocolate or milk powder), lockable
- Coffee grounds ejector
- Cup sensor
- M2M/telemetry
- Billing systems
- Raised feet (100 mm)
- Autosteam steam spout (enhanced milk foaming) or Autosteam Pro (automatic milk foaming)





**FLAVOR-STATION**

Automatic dosing station for up to three flavors

**CUP WARMER**

With four heatable trays

PRODUCT SPECIALTIES	A600	A600 MS	A600 FM
Ristretto   Espresso	✓	✓	✓
Coffee   Café crème	✓	✓	✓
Brewed coffee	✓	✓	✓
Cappuccino   Latte macchiato	(✓)	✓	✓
Chococcino	(✓)	✓	✓
Chocolate	✓	✓	✓
Hot milk	(✓)	✓	✓
Hot milk foam	(✓)	✓	✓*
Cold milk		✓	✓
Cold milk foam			✓*
Flavors			✓
Hot water   Steam	✓	✓	✓

\* Licensed by Thermoplan



**COLORS**

In addition to the original matt gray color, the machine components shown here are now also available in gloss black:

- MS and FM milk systems
- A600, A600 MS, A600 FM
- Flavor-Station
- Billing system
- Cup warmer

# FOR COMPLETE FLEXIBILITY

Tailored precisely to your needs.

The following accessories can be combined with the A600:



## **KE200 THE MINI MARVEL**

- Refrigeration unit (4l), lockable
- Suitable for small to mid-range capacities
- Manual cleaning



## **CHILL & CUP THE SPACE-SAVER**

- Combination of lockable refrigeration unit (5l) with two heatable cup racks (80 cups)
- Suitable for small to mid-range capacities



## **BASE REFRIGERATION UNIT (UKE) THE SPACE MAGICIAN**

- Refrigeration unit (5l), lockable
- Suitable for use as a machine base (for professional food service or convenience applications)
- Suitable for mid-range capacities when space is limited on the counter





**UNDER THE COUNTER  
REFRIGERATION UNIT (UT320)  
THE VOLUME KING**

- Refrigeration unit (12l), lockable
- Installation under the counter, directly underneath the coffee machine
- Suitable for high capacities when space is limited on the counter



**FLAVOR-STATION  
THE FLAVOR WIZARD**

- Dosing station with three syrups, automatic dosing, lockable
- Can also be fitted with liquors
- Available with heatable cup storage on upper shelf, with on/off switch



**BILLING SYSTEM  
THE MONEY MAESTRO**

- Can be used for various payment methods, e.g. with coins, card, cell phone etc.
- Ideally suited for public/private vending applications
- Can be combined with M2M features

# TECHNICAL DATA FOR A600 WITH ACCESSORIES, PLUS ADDITIONAL COMPATIBLE ACCESSORIES

## MACHINE MODELS

MODEL	POWER
A600	2.4-2.8 kW
A600 MS	2.4-2.8 kW
A600 FM	2.4-2.8 kW

(other connection types upon request)

## ACCESSORIES

A600	POWER
4) Billing system	Depends on system
Cup warmer (120 cups)	120 W
A600 MS	POWER
1) Refrigeration unit SU05 (5 l)	72 W
4) Billing system	Depends on system
Cup warmer (120 cups)	120 W
A600 FM	POWER
2) Refrigeration unit SU05 (5 l)	1.95-2.3 kW
3) Flavor-Station (3 flavors)	75 W
4) Billing system	Depends on system
Cup warmer (120 cups)	120 W

## COLOR OPTIONS

Matt gray (original color) or gloss black

## ELECTRICAL CONNECTION

On all models and devices 200-240 V 1LNPE 50/60 Hz 10 A

## WATER CONNECTION

Fixed water connection	Metal hose with union nut G 3/8", L = 1.5 m
Water supply line	If possible on installation side: untreated water (not from household decalcification system)
Water pressure	80 to 800 kPa (0.8 to 8.0 bar)
Water hardness	max. 70 mg CaO per liter of water (7 dH, 13 °fH)
Chloride content	max. 100 mg/l
Ideal pH value	7

## WATER DRAIN

Drain hose Dia. = 16 mm, L = 2000 mm

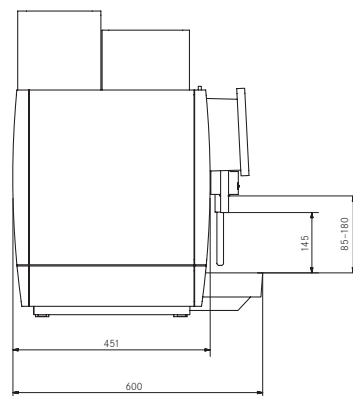
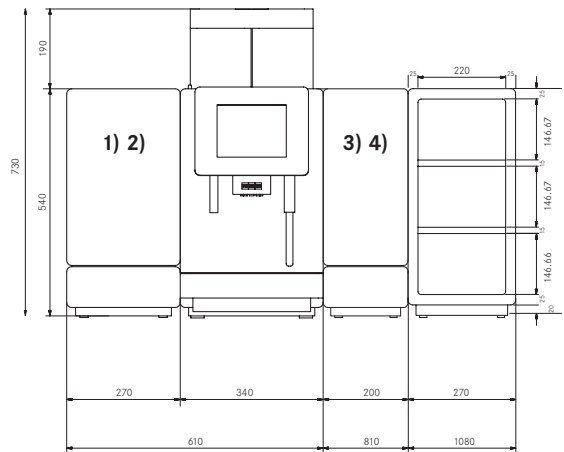



### KE 200

Electrical connection:	220-240 V 1LNPE 50/60 Hz 10 A
Power:	90 W
Dimensions:	225 mm / 330 mm / 453 mm (W/H/D)
Weight (empty):	approx. 13 kg
Compatible with:	Model A600 MS
Color:	Stainless steel

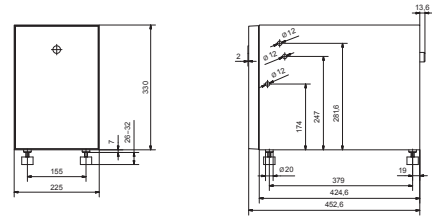

### CHILL & CUP

Electrical connection:	220-240 V 1LNPE 50/60 Hz 10 A
Power:	170 W
Dimensions:	334 mm / 502 mm / 471 mm (W/H/D)
Weight (empty):	approx. 29 kg
Compatible with:	Model A600 MS
Color:	Stainless steel

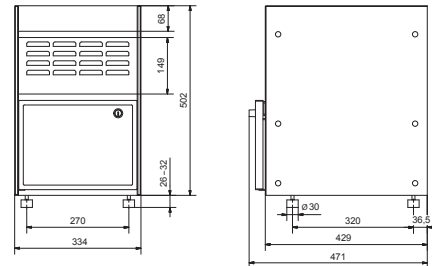

### BASE REFRIGERATION UNIT (UKE)

Electrical connection:	230 V 1LNPE 50/60 Hz 10 A
Power:	90 W
Dimensions:	320 mm / 238 mm / 646 mm (W/H/D)
Weight (empty):	approx. 27 kg
Compatible with:	Model A600 MS
Color:	Stainless steel

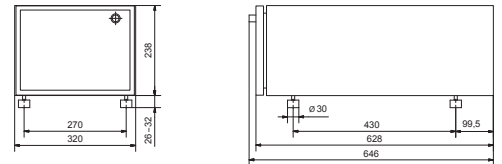

### UNDER THE COUNTER REFRIGERATION UNIT (UT320)

Electrical connection:	230 V 1LNPE 50/60 Hz 10 A
Power:	100 W
Dimensions:	320 mm / 547 mm / 467 mm (W/H/D)
Weight (empty):	approx. 26 kg
Compatible with:	Model A600 MS
Color:	Stainless steel

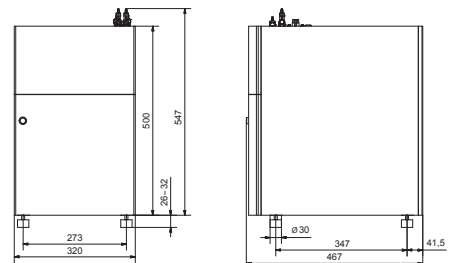

### FLAVOR-STATION

Electrical connection:	100-240 V 1LNPE 50/60 Hz 10 A
Power:	75 W
Dimensions:	200 mm / 542 mm / 451 mm (W/H/D)
Weight (empty):	approx. 18 kg
Compatible with:	Model A600 FM
Color:	Matt gray or gloss black

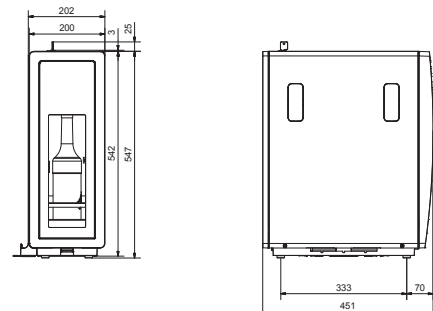

### BILLING SYSTEM

Electrical connection:	85-264 V 1LNPE
Power:	Depends on system
Dimensions:	200 mm / 542 mm / 451 mm (W/H/D)
Weight (empty):	approx. 18 kg
Compatible with:	Model A600, A600 MS, A600 FM
Color:	Matt gray or gloss black

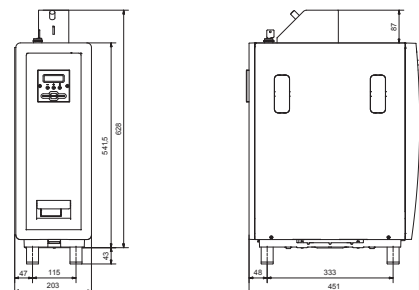



Franke Kaffeemaschinen AG  
Franke Strasse 9  
4663 Aarburg  
Switzerland  
Fon +41 62 787 31 31  
[www.franke.com](http://www.franke.com)

Franke Coffee Systems GmbH  
Franke Strasse 1  
97947 Grünsfeld  
Germany  
Fon +49 9346 9278 0  
Fax +49 9346 9278 100  
[www.franke.de](http://www.franke.de)

Franke Coffee Systems  
UK Ltd  
18 Handley Page Way,  
Old Parkbury Lane,  
St Albans,  
Hertfordshire AL2 2DQ  
England  
Fon +44 1923 635700  
Fax +44 1923 635701  
[www.franke.com](http://www.franke.com)

Franke Japan Inc.  
Amflat, 12-35-12  
Nihonbashi Ningyocho, Chuo,  
Tokyo 103-0013  
Japan  
Fon +81 3 5642 5880  
[www.franke.com](http://www.franke.com)

Franke Coffee Systems  
Americas  
800 Aviation Parkway  
Smyrna, TN 37167  
USA  
Fon +1 615 462 4265  
Fax +1 615 462 4400  
[www.franke.com](http://www.franke.com)

**FRANKE**